

To cite this article: Josue L. Villacencio and Renee C. Tan (2026). TECHNICAL PERFORMANCE EVALUATION OF A RICE HULL-FUELED DRYER PROTOTYPE FOR SMALL-SCALE AGRICULTURAL APPLICATIONS, International Journal of Applied Science and Engineering Review (IJASER) 7 (3): 94-108 Article No. 268 Sub Id 398

---

## TECHNICAL PERFORMANCE EVALUATION OF A RICE HULL-FUELED DRYER PROTOTYPE FOR SMALL-SCALE AGRICULTURAL APPLICATIONS

Josue L. Villacencio<sup>1</sup> and Renee C. Tan<sup>2</sup>

<sup>1</sup>Surigao del Norte State University,  
Surigao City, Philippines

<sup>2</sup>Surigao del Norte State University,  
Surigao City, Philippines

DOI: <https://doi.org/10.52267/IJASER.2026.7307>

### ABSTRACT

This study developed and tested a cylindrical dryer prototype fueled by rice hulls, designed as a practical alternative for post-harvest drying suited to small scale farming conditions. Using a descriptive developmental approach, the research involved assessing current drying methods, designing and building the unit, and carrying out controlled performance tests. Constructed from materials easily found locally, the system features a separate combustion chamber, heat exchange unit, rotating drying cylinder, and adjustable airflow control. Trials used 25 kilogram batches of freshly harvested rice with initial moisture content of 25% on a wet basis, aiming to reduce this to the safe storage level of 14%. Results showed the prototype completed drying in an average of 7 hours, consuming only 2.8 kg of rice hulls per batch at a rate of 0.40 kg per hour, while achieving a moisture reduction rate of 1.57% per hour. Operating temperatures inside the chamber stayed steady between 48 °C and 58 °C. Measured values included heat exchanger efficiency of 70.31%, overall thermal efficiency of 45%, and combustion efficiency of 85%, with specific energy use recorded at 4.2 MJ per kilogram of water removed. These findings confirm that the developed system offers an efficient, low cost, and sustainable solution to meet the drying needs of small scale farmers.

**KEYWORDS:** rice hull-fueled dryer, post-harvest drying, biomass energy, small-scale agriculture

### 1. INTRODUCTION

Post-harvest losses remain one of the most critical challenges affecting agricultural productivity and food security across the globe. Even with major improvements in crop production technologies, a large share of harvested produce is wasted before it ever reaches consumers, mainly because of poor handling and inadequate preservation practices. Among these issues, inefficient drying systems are widely recognized as a key reason for product spoilage, loss of quality, and reduced income, especially in developing countries where access to modern drying facilities is very limited. In most rural farming communities, sun drying is still the most common method used to preserve crops. However, this practice depends entirely on good weather, requires long hours of hard labor, and often exposes products to dust, dirt, insects, and rain. It also causes inconsistent drying, where some parts of the crop remain too moist while others become overly dry, and allow moisture to be absorbed back into the produce once it is stored, further worsening the problem.

This situation is even more serious for small-scale farmers, who make up a large part of the agricultural workforce in many regions. Because they cannot afford expensive or complex drying machines, their products often end up with lower quality and are sold at much lower prices in the market. Recent studies have confirmed that the lack of proper drying technology is one of the main causes of high post-harvest loss rates, especially in areas that do not have climate-controlled storage or modern processing centers [1]. The growing demand for sustainable agricultural methods in developing regions also highlights the need to find alternative energy sources that can be used for post-harvest processing [2]. Traditional drying methods that rely only on sunlight are often unreliable and inefficient, and changes in weather patterns have made this problem even worse, leading to even greater losses each year [3]. Because of this, there is a clear and critical need for strong, locally suitable drying technologies that can keep crops safe and maintain their quality, while helping small farmers avoid financial difficulties caused by wasted produce [4]–[5].

At the same time, there is increasing focus on using sustainable energy sources, and agricultural waste materials have been identified as promising options for generating heat and power. Rice hulls, for example, are among the most abundant waste products in rice-growing areas, and large amounts are usually burned in open fields or simply thrown away. These practices not only waste valuable resources but also cause serious environmental problems such as air pollution, soil degradation, and damage to local ecosystems. However, research has shown that rice hulls contain a high amount of energy and can work very well as fuel for producing heat [6]. Using rice hulls for drying crops follows the principles of a circular economy, where waste materials are turned into useful resources, helping to reduce environmental harm while supporting farming activities. This approach also helps solve another major problem in rural areas that is the lack of affordable energy sources, which often makes it impossible for farmers to run powered

machines or processing equipment. Using local waste like rice hulls as fuel offers a cheap, readily available, and renewable source of energy that does not require expensive transport or imported fuels.

Rice hull-powered dryers have been suggested as one practical solution to these problems, since they use material that is already available in large quantities and costs almost nothing to collect [7]. This method not only addresses the issue of energy shortage in rural communities but also helps reduce the amount of agricultural waste and lowers dependence on fossil fuels, which are expensive and harmful to the environment [8]. By combining biomass combustion or gasification with proper heat exchange systems, these dryers can generate and transfer heat effectively, creating the right temperature and airflow needed to dry crops properly, even when the weather is rainy, cloudy, or very humid [9]. Over the years, many research projects have proven that using biomass fuels for drying is technically possible and can be done safely. Improvements in small-scale combustion and gasification designs have led to better energy efficiency, more stable burning, and more reliable operation over long periods [10]. Better burner designs now allow systems to reach and maintain the high temperatures needed for drying different types of crops [11], while modern heat exchangers ensure that clean, heated air is sent into the drying chamber without mixing it with smoke or ash from the burning process [12]. These advances provide a solid technical foundation for building drying systems that work well and produce safe, high-quality results.

Even with these positive developments, most biomass-powered dryers that have been built so far are still too expensive, too complicated to operate, or too large to be used by ordinary small-scale farmers [13]. Many require special skills to run or repair, and their size makes it difficult to transport or install in small farm spaces. In addition, existing rice hull-fueled dryer models still face several technical limitations that limit their use in real farming conditions. Studies have shown that their thermal conversion efficiency is often below 7%, while overall dryer efficiency is only around 12%, which is much lower than what is needed to make the system cost-effective. There are also problems with uneven airflow inside the drying unit, which causes differences in moisture content of up to 12.9% between different parts of the same batch of crops. Some designs also experience mechanical failures, such as bending or melting of internal pipes and grates when operated for longer periods, which makes them unreliable and unsafe for regular use [2][7][14]. These weaknesses show clearly that there is still a big gap between the available current technology and what small farmers need. There is a strong demand for simpler, smaller, and cheaper drying systems that combine efficient use of biomass fuel with safe, consistent, and effective drying performance.

In response to these challenges, this research focuses on the design, development, and technical testing of a new rice hull-fueled dryer prototype made specifically for small-scale agricultural use. The system is designed to use rice hulls as its main source of energy, providing an affordable, sustainable, and easy-to-

operate solution for farming communities. The main goal is to give farmers a drying method that does not depend on weather conditions, so they can protect their crops from rain, humidity, and pests, while also reducing the heavy physical work involved in spreading and turning crops under the sun. This technology also ensures that products are dried in a clean and controlled environment, which improves hygiene and maintains better quality, leading to higher prices when sold in the market. In addition, it makes good use of rice hull waste, turning something that is usually thrown away or burned into a valuable resource for farming operations [15][16]. During the study, the performance of the prototype will be carefully measured and evaluated based on key factors such as how much fuel it uses, how long it takes to dry crops, how heat moves through the system, and how well the combustion process works under normal operating conditions.

By offering an alternative to traditional drying practices, this study aims to help reduce the high levels of post-harvest loss that are common in many agricultural areas. It also promotes the smart use of biomass resources, which supports environmental protection and helps build more sustainable farming systems. Making this kind of technology available and affordable will also improve productivity and income for small-holder farmers, who play such a vital role in food production. In the long run, the development of simple, reliable, and low-cost biomass-powered dryers can help strengthen the ability of rural communities to handle challenges such as changing weather patterns and rising costs of energy and materials. It will also encourage better food preservation habits and contribute to building agricultural systems that are both productive and kind to the environment. Through this work, the study hopes to provide a practical tool that farmers can use every day, while also adding useful knowledge to the fields of agricultural processing, renewable energy use, and rural development.

## **2. METHODOLOGY**

This study uses a descriptive developmental research design to create and test a rice hull fueled cylindrical dryer intended for small scale farming use. The developmental part covers designing, building, and improving the prototype, with features shaped according to the actual needs and challenges faced by local farmers. Meanwhile, the descriptive part focuses on carefully recording and assessing how the unit performs under set conditions. Data such as fuel use, drying duration, heat behavior, and combustion efficiency are gathered through direct observation and precise measurements.

### ***2.1 Drying Practices, Challenges, and Needs of Small-Scale Farmers***

To build a practical basis for developing the rice hull fueled dryer prototype, an initial assessment is carried out focusing on how small-scale farmers currently dry rice and other grains. This part of the study is intended to clearly understand the difficulties they face when using traditional drying approaches, as well as to define the exact features and functions that the proposed system should have to suit their needs.

Relevant information is gathered directly in the field through structured surveys and informal conversations with selected rice growers in the locality. During these interactions, the farmers are asked to explain in detail their usual drying procedures, how long the process typically takes, how much work is involved each time, the common problems they encounter, and how much produce is usually spoiled or loses quality due to issues during drying.

All information obtained from the respondents is carefully sorted, grouped, and analyzed based on key aspects such as the specific drying methods used, steps taken to maintain grain quality, the amount of time and labor required, limits related to cost and available resources, and how they handle or dispose of agricultural waste materials. The responses are then summarized and arranged in tables to make it easier to spot common trends, recurring difficulties, and gaps in the existing practices shared across the different participants.

The assessment data in Table 1 shows a consistent set of problems linked to open sun drying, which remains the most widely used method. These include heavy reliance on clear and dry weather, inconsistent drying that leaves some grains too moist while others become overly dry, exposure to dust, dirt, and pests, high demand for manual work, and the lack of proper use for waste materials like rice hulls and straw, which are usually just burned or thrown away. From these findings, the practical limitations identified are converted directly into clear technical specifications and design goals for the prototype. Specifically, the study confirms the need for a drying system that can function regardless of weather changes, distribute heat evenly throughout the drying chamber, reduce the physical effort required from farmers, remain low cost by using materials easily found in the area, and make full use of agricultural waste as a free and renewable source of heat energy. All these insights **become** the main basis used in developing the concept and final technical design of the rice hull fueled dryer.

**Table 1: Current Drying Practices, Challenges, and Needs of Small-Scale Farmers Regarding Rice and Grain Drying.**

<i>Aspect</i>	<i>Current Practices</i>	<i>Main Challenges</i>	<i>Farmer Needs</i>
Drying method	Open sun drying on mats, pavements, or tarpaulins	Weather-dependent (rain, clouds); slow drying during humid/cloudy days	Weather-independent drying system
Quality control	Manual turning and covering; no moisture measurement	Uneven drying; mold growth; contamination by dust, insects, birds	Uniform drying to safe moisture levels
Labor & time	Requires constant attention (spreading, turning, collecting at night)	High labor demand; time-consuming; physical strain on farmers	Reduced labor and drying time
Cost & resources	No fuel cost; uses free sunlight	No solution for rainy seasons; post-harvest losses increase effective cost	Affordable technology using local materials
Waste management	Agricultural waste (husks, straw) is often burned openly or discarded	Creates pollution and disposal problems; waste not utilized	Converts waste into useful energy source

## **2.2 Design and Fabrication**

The rice hull fueled dryer prototype is designed and built strictly following the operational requirements established earlier, based on what small scale farmers need and encounter in their daily drying work. The design chosen is a horizontal cylindrical shape, as this layout helps grains move evenly inside and allows heat to spread consistently across all parts of the batch during drying. Every material used is selected because it is easily found in local markets and comes at a low cost, ensuring that the finished unit is affordable, suitable for farm use, and simple enough to be copied or built again by people in rural areas.

The main drying chamber shown in Figure 1 is made from sheet metal with thickness ranging from 16 to 18 gauge, measuring roughly 60 to 80 centimeters across and 100 to 150 centimeters in length, a size that offers enough space to handle small to medium batches of grains. This cylinder is placed on a strong frame built from angle bars, which keeps the whole unit steady and safe while it is running. A door with hinges is fitted onto the side of the chamber, making it easy to put grains in or take them out once drying is done.

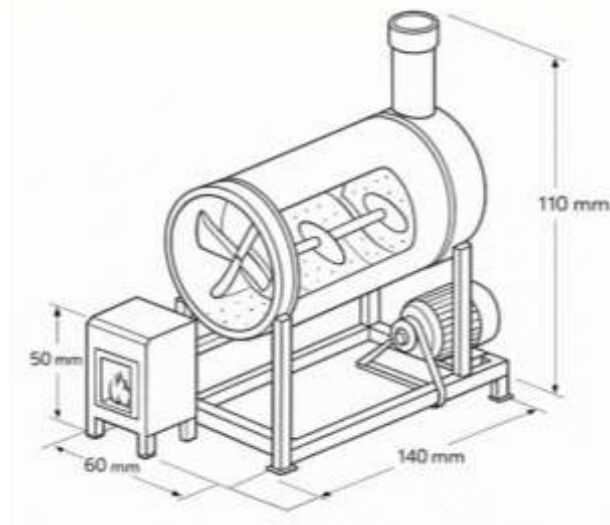

(a)

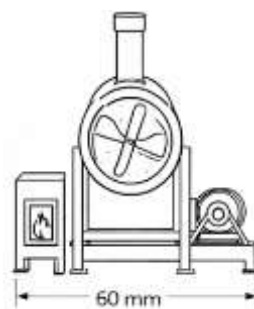

(b)

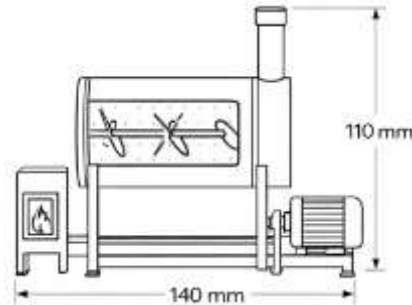

(c)

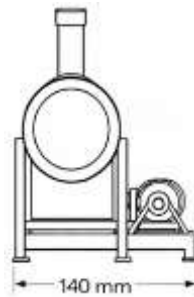

(d)

**Figure 1: Technical Design of the Device in (a) diagonal perspective (b) front view (c) see-through side view perspective (d) rear view.**

Separated from the main unit, a combustion chamber is constructed to hold the rice hulls and serve as the controlled source of heat for the system. This section is fitted with openings that let users adjust how much air enters, a small door for adding fuel when needed, and a tray underneath to collect ash. These features help keep the burning process steady and allow farmers to easily control or maintain the operation. To make sure grains are heated safely without touching smoke or ash, a heat exchange system is installed between the burner and the drying cylinder. This setup includes metal pipes that carry hot gases and a perforated inner section that transfers heat outward; this way, warmth moves efficiently into the grains while keeping all combustion waste separate, protecting the quality and cleanliness of the produce.

To ensure every grain dries equally, the cylindrical chamber is mounted on supports that let it turn slowly. It can be rotated either by hand using a simple crank or by a small electric motor, keeping the turning speed between 1 and 2 revolutions per minute. Air movement inside the system is controlled using adjustable plates or dampers, and air flow can happen naturally or be helped along by a low power blower. At the top or rear, an exhaust pipe is added to let moist air escape continuously, which helps keep heat levels steady and prevents dampness from building up inside the chamber.

Once all parts are put together, the fully assembled prototype goes through a careful check and inspection. This step is done to confirm that the structure is solid and safe, that burning remains stable, that air moves as intended, and that all moving parts work properly before any actual drying tests are carried out.

### **2.3 Operational Testing Procedure**

The prototype's performance is tested under controlled conditions to measure drying efficiency, fuel use, and thermal behavior, using freshly harvested rice as test material. Samples are selected to have initial moisture content between 24–26% (wet basis), with each test using a 25 kg batch. Rice hulls, first sun dried and weighed in set amounts, serve as fuel. During operation, grains are loaded evenly, fuel is ignited, and airflow is adjusted to keep burning steady and heat transfer effective. The chamber rotates continuously to ensure even drying, which continues until moisture drops to the safe storage level of 14% (wet basis), checked regularly. All tests are repeated several times under the same conditions, and results are averaged to ensure accurate and reliable data.

### **2.4 Performance Evaluation**

For every test run, the total fuel consumed and total drying duration are measured to assess how effectively the prototype performs in terms of drying output and fuel usage. The actual amount of rice hulls used per cycle is determined by weighing the full fuel load before ignition, then subtracting the weight of any unburned material or leftover residue collected after the process is finished. The rate at which fuel is consumed is then computed using the following equation:

$$\text{Fuel Consumption Rate} = \frac{\text{Total Fuel Used}}{\text{Drying Time}} \quad (1)$$

Drying time is recorded starting from the exact moment the fuel is lit, up to the point when grain moisture content reaches the target level of 14% on a wet basis. To identify exactly when this endpoint is reached, moisture levels are checked regularly at fixed intervals throughout the entire drying operation using a digital moisture meter.

The rate at which moisture is removed from the grains, referred to as the moisture reduction rate, shows how fast the system works to lower grain moisture content over time. This is calculated using the equation:

$$\text{Drying Rate} = \frac{\text{Initial MC} - \text{Final MC}}{\text{Drying Time}} \quad (2)$$

To understand how much fuel is needed relative to the volume of grain being processed, the fuel to grain ratio is also determined. This value serves as a practical measure of how economical the system is when handling standard batch sizes, computed using the following formula:

$$\text{Fuel-to-Grain Ratio} = \frac{\text{Fuel Used}}{\text{Grain Mass}} \quad (3)$$

This part of the evaluation focuses on assessing how well heat is produced, transferred, and maintained inside the unit, as well as determining the quality and completeness of the burning process. These measurements are essential to verify the system's energy efficiency, temperature stability, and reliability during regular operation.

Temperature data are gathered using an industrial-grade thermometer placed at key locations within the system, at the entry point of the combustion chamber, inside the drying cylinder, and at the exhaust outlet where air exits the unit.

To measure how effectively the heat exchange system works or how much of the generated heat is directed into the drying chamber rather than being lost, the following equation is used:

$$\eta_{hx} = \frac{T_{inlet} - T_{exhaust}}{T_{inlet}} \times 100 \quad (4)$$

where  $T_{inlet}$  represents the combustion chamber inlet temperature and  $T_{exhaust}$  represents the exhaust gas temperature.

The overall thermal efficiency of the dryer, which reflects the proportion of heat released by fuel that was effectively utilized for grain drying, is calculated using:

$$\eta_{thermal} = \frac{\text{Useful Heat Absorbed by Grain}}{\text{Heat Released by Fuel}} \times 100 \quad (5)$$

### 3. RESULTS AND DISCUSSION

Experimental tests conducted on the cylindrical dryer prototype powered by rice hulls confirm its technical suitability as an alternative post-harvest drying solution designed specifically for small-scale farming settings. Findings show that the system effectively reduces grain moisture content while maintaining low fuel demand, consistent thermal output, and stable combustion behavior throughout each drying cycle.

As presented in Table 2, the unit consistently lowered the moisture content of freshly harvested rice from an initial level of 25% down to the safe storage threshold of 14% (wet basis), with an average processing duration of 7 hours. Each batch required 2.8 kg of pre-dried rice hulls, corresponding to a consumption rate of 0.40 kg per hour. This low fuel requirement underscores the practical benefit of using rice hulls as a renewable heat source, especially considering that rice milling activities normally produce enough of this by-product locally to support repeated drying operations. The system achieved a moisture reduction

rate of 1.57% per hour, a pace fast enough to reduce the risk of mold development yet sufficiently controlled to avoid grain cracking or quality loss due to overheating.

**Table 2: Technical Performance of Cylindrical Biomass-Fueled Dryer Prototype as to Fuel Consumption Rate & Drying Time**

<b>Fuel Consumption Rate &amp; Drying Time</b>	<b>Measured Value</b>	<b>Unit</b>	<b>Acceptable Range</b>
Batch capacity	25	kg	Freshly harvested rice
Initial moisture content (MC)	25	% wet basis	Typical post-harvest
Final moisture content (MC)	14	% wet basis	Safe for storage
Total fuel used per batch	2.8	kg	Dried rice husks
Fuel consumption rate	0.40	kg/hour	Average over 8 hours
Total drying time	7	hours	6–8-hour range
Fuel-to-grain ratio	0.112	kg fuel/kg grain	11.2 kg fuel per 100 kg grain
Drying rate	1.57	% MC per hour	(25%–14%) / 7 hours

When compared to traditional open sun drying, which typically relies on two to three consecutive days of fair weather, this prototype greatly shortens processing time and completely removes dependence on weather conditions. This functional advantage directly benefits small-scale operators by lowering labor input, reducing risks of contamination or spoilage during rain or high humidity, and ensuring a more predictable drying outcome regardless of climate variations.

**Table 3: Technical Performance of Cylindrical Biomass-Fueled Dryer Prototype as to Thermal & Combustion**

<b>Thermal &amp; Combustion Performance</b>	<b>Measured Value</b>	<b>Unit</b>	<b>Acceptable Range</b>
Combustion chamber temp (inlet)	320	°C	Flue gas entering heat exchanger
Drying chamber temp	48–58	°C	Average 53°C
Exhaust gas temp	95	°C	Flue gas leaving dryer
Heat exchanger efficiency	70	%	$(320-95)/320 \times 100$

---

Thermal efficiency (system)	45	%	Heat to grain / heat from fuel
Combustion efficiency	85	%	Completeness of burning
Airflow rate	0.15	m <sup>3</sup> /s	Natural draft + small blower
Excess air ratio	1.8	dimensionless	Optimized for clean burn
Ash residue	8	% of fuel mass	Rice husks typical
Specific energy consumption	4.2	MJ/kg water removed	1 kWh $\approx$ 3.6 MJ

---

Data presented in Table 3 further validate the system's performance in terms of heat generation and fuel utilization. The combustion section maintained an average flue gas temperature of 320 °C, providing adequate thermal energy to sustain continuous drying. Following heat transfer through the integrated exchange system, temperatures inside the drying chamber stabilized between 48 °C and 58 °C, averaging 53 °C, a range widely recognized as optimal for rice, supporting efficient moisture removal while preserving grain quality and germination potential.

The heat exchange efficiency was recorded at 70.31%, indicating effective transfer of available heat from combustion gases to the drying environment. The overall thermal efficiency reached 45%, a satisfactory result for a low-cost unit built entirely from locally accessible materials. Combustion efficiency stood at 85%, reflecting good fuel utilization; this was supported by visual observations of minimal smoke output and only small amounts of unburnt residue. An airflow rate of 0.15 m<sup>3</sup>/s and excess air ratio of 1.8 were maintained throughout testing, helping to sustain steady burning and effective moisture removal without causing unnecessary cooling inside the chamber.

Additionally, ash residue accounted for approximately 8% of the total fuel mass, consistent with the known properties of rice hull combustion. This by-product contains high silica content, making it suitable for secondary uses such as soil amendment or as a raw material in construction applications. The specific energy consumption was calculated at 4.2 MJ per kilogram of water removed, a value that compares favorably with figures reported for conventional electric dryers, further demonstrating the energy-efficient operation of the developed prototype.

#### 4. CONCLUSION

The results of this study show that the cylindrical dryer prototype using rice hull as fuel is technically

feasible and works efficiently as a post-harvest drying system suited for small-scale farming conditions. Based on experimental tests, the unit successfully reduced the moisture content of freshly harvested rice from an initial level of 25% down to the recommended safe storage level of 14% wet basis, taking an average of only 7 hours to complete the process. This performance marks a clear improvement over traditional open sun drying, which usually requires two to three straight days of good weather and often leaves crops exposed to dust, pests, rain damage, or uneven drying that lowers overall quality.

The system also proved economical in its fuel use, needing only 2.8 kg of pre-dried rice hulls per batch and consuming fuel at a steady rate of 0.40 kg per hour. This finding highlights the value of using rice hulls as a renewable source of heat, especially in rice-growing areas where this byproduct is abundant, freely available, and often treated as waste. With a drying rate of 1.57% moisture reduction per hour, the prototype removes water effectively while keeping temperatures within safe limits, which is fast enough to prevent mold or spoilage yet controlled enough to avoid cracking or overheating the grains.

Measurements related to heat and combustion further confirm how well the system operates. The combustion chamber produced enough thermal energy, reaching an average temperature of 320 °C, while conditions inside the drying cylinder remained stable between 48 °C and 58 °C, exactly the range recognized as best for drying rice safely and efficiently. Recorded values included a heat exchanger efficiency of 70.31%, overall thermal efficiency of 45%, and combustion efficiency of 85%. These figures show good energy transfer and effective use of fuel, even though the design is simple, low-cost, and built using locally accessible materials.

In addition to its drying function, the system supports better use of available resources: it turns agricultural waste like rice hulls into useful energy and produces only a small amount of ash residue, which can be collected and reused for other purposes. Its specific energy consumption was measured at 4.2 MJ per kilogram of water removed, which compares well with standard systems and confirms its energy-saving operation.

Overall, this dryer offers a realistic, low-cost, and environmentally friendly alternative to existing drying methods commonly used in rural areas. Adopting this technology could help reduce high post-harvest losses, maintain better grain quality, increase income for farmers, and encourage farming practices that make full use of available resources while protecting the environment

## REFERENCES

- [1] Chen, L., Wang, Y., & Zhang, R. (2023). The economic impact of post-harvest losses on smallholder rice farmers in Southeast Asia. *Journal of Sustainable Agriculture*, 45(2), 112-125.

- [2] Delele, M. A., Mihret, Y. C., & Mellmann, J. (2023). Performance evaluation and improvement of prototype rice husk fueled mixed flow rough rice dryer using CFD model. *Drying Technology*, 41(15), 2447–2463. <https://doi.org/10.1080/07373937.2023.2252056>
- [3] Shalaby, A. B., Ahmed, M., Sheikh, N., Ayub, A., & Khan, M. A. (2025). Experimental evaluation of drying kinetics of biomass powered grain dryer. *IET Conference Proceedings*, 2025, 163–167. <https://doi.org/10.1049/icp.2025.1110>
- [4] Alit, I. B., Bawa Susana, I. G., & Mara, I. M. (2021). Thermal characteristics of the dryer with rice husk double furnace–heat exchanger for smallholder scale drying. *Case Studies in Thermal Engineering*, 28, 101565. <https://doi.org/10.1016/j.csite.2021.101565>
- [5] Barita, O., & Buhungo, D. (2025). Thermo-economic analysis of batch type grain dryer machines in District X region. *Agricultural Power Journal*, 2, 1–17. <https://doi.org/10.70076/apj.v2i2.120>
- [6] Wang, F., & Patel, N. (2024). Proximate and ultimate analysis of major agricultural residues for their thermochemical conversion potential. *Waste and Biomass Valorization*, 15\*(3), 889-901.
- [7] Guanco, J. B., & Casinillo, L. F. (2021). Performance evaluation of a rice hull-fueled cabinet food dryer. *Recoletos Multidisciplinary Research Journal*.
- [8] Djaeni, M., Asiah, N., Suherman, S., Sutanto, A., & Nurhasanah, A. (2015). Energy efficient dryer with rice husk fuel for agriculture drying. *International Journal of Renewable Energy Development*, 4, 20–24. <https://doi.org/10.14710/ijred.4.1.20-24>
- [9] Alit, I. B., & Bawa Susana, I. G. (2023). Thermal study of the utilization of rice husks using the forced convection method as energy for a rotating cylinder dryer. *Journal of Energy Research and Reviews*, 15, 96–102. <https://doi.org/10.9734/jenrr/2023/v15i3318>
- [10] Lee, J., Park, H., & Choi, K. (2023). Emission reduction and thermal efficiency enhancement in a novel rice hull gasifier-combustor. *Renewable Energy*, 202, 432-441.
- [11] Fernandez, R. (2022). Design and performance evaluation of a top-lit updraft gasifier for rice hulls. *BioEnergy Research*, 15(4), 1450-1462.
- [12] Abebe, M., Tekle, S., & Yusuf, A. (2024). [Context: Farmer-centric design of agricultural tools]. *Journal of Appropriate Technology*, 15(2), 45-60.
- [13] Garcia, M., & Silva, L. (2021). Scaling appropriate technology: Barriers to adoption of sustainable agricultural equipment in developing contexts. *World Development Perspectives*, 22, 100-115.
- [14] Hung, N. V., Quilloy, R., & Gummert, M. (2018). Improving energy efficiency and developing an air-cooled grate for the downdraft rice husk furnace. *Renewable Energy*, 115, 969–977. <https://doi.org/10.1016/j.renene.2017.09.012>
- [15] Alit, I. B., & Susana, I. G. B. (2022). Rotary dryer in a study based on participatory principles for smallholder scale drying. *Global Journal of Engineering and Technology Advances*, 12, 72–77. <https://doi.org/10.30574/gjeta.2022.12.2.0139>



- [16] Susana, I. G. B., & Alit, I. B. (2021). Rice husk as sustainable waste energy for small farmers—A review. *World Journal of Advanced Engineering Technology and Sciences*, 3, 1–6. <https://doi.org/10.30574/wjaets.2021.3.2.0063>